

# FOR LEASE 2,125± SF

## OFFICE/WAREHOUSE SPACE

MCDOWELL MOUNTAIN BUSINESS PARK | SCOTTSDALE AIRPARK SUBMARKET

16585 N 92ND ST. | SUITE B104 | SCOTTSDALE, ARIZONA 85260

I-1 LIGHT INDUSTRIAL ZONING



### FEATURES:

- Two (2) private offices
- Open flex entry area
- Kitchenette/break
- Private restroom
- Evap-cooled warehouse with 12'x14' roll-up door & two (2) skylights for great natural lighting
- ±22' ceiling height in warehouse

FOR MORE INFORMATION PLEASE CONTACT:



**RANDY SHELL**

Designated Broker

O 480.443.3992

C 480.694.4100

[randy@shellcommercial.com](mailto:randy@shellcommercial.com)



**AMANDA WRIGHT**

Senior Associate

O 480.443.3992

C 480.236.0037

[amanda@shellcommercial.com](mailto:amanda@shellcommercial.com)



480.443.3992 [www.shellcommercial.com](http://www.shellcommercial.com)

16410 N 91st St | Suite 112 | Scottsdale, AZ 85260

16585 N 92ND ST. | SUITE B104 | SCOTTSDALE, ARIZONA 85260

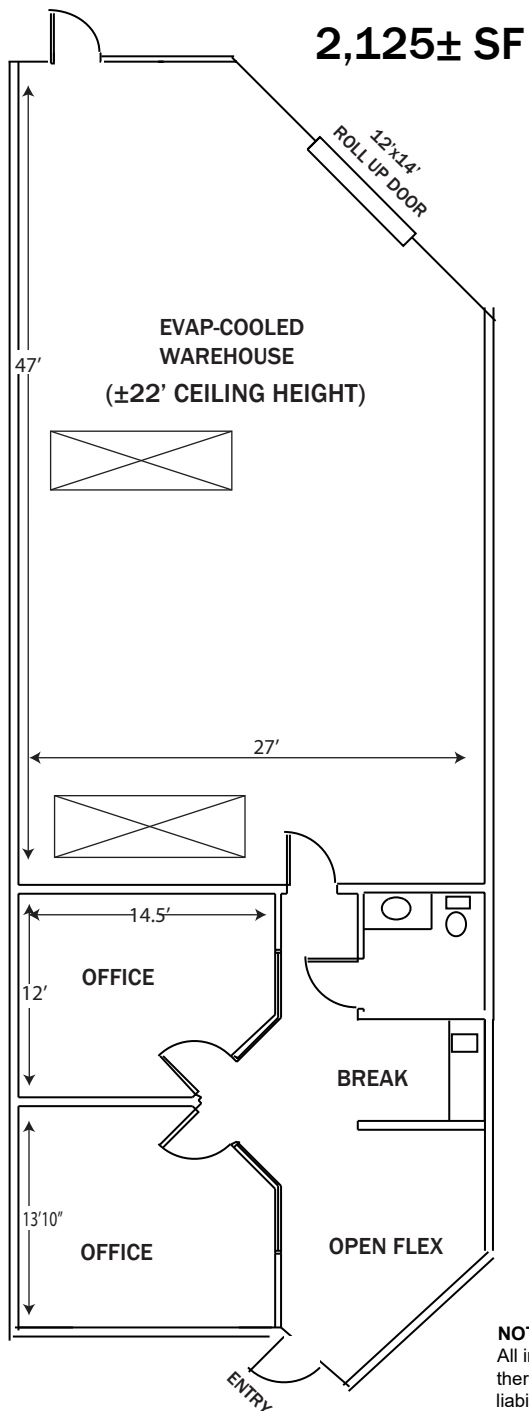

**EXCELLENT NORTH SCOTTSDALE LOCATION WITH EASY ACCESS TO LOOP 101 INTERCHANGE**



**NOT TO SCALE**

All information furnished regarding property for sale, rental or financing is from sources deemed reliable, but no warranty or representation is made to the accuracy thereof and same is submitted to errors, omissions, change of price, rental or other conditions, prior to sale, lease or financing or withdrawal without notice. No liability of any kind is to be imposed on the broker herein. This information has been secured from sources deemed reliable, however, we make no warranties as to its accuracy.